



The Step-In Tub Experts!

CLEANCUT DEEP STEP INSTALLATION GUIDE

DO IT YOURSELF



Scan QR Code with phone camera to watch **video instructions** or visit www.cleancutbath.com for more resources

NEED A PRO?



Interested in professional installation?
Scan the QR Code and enter in your zip code to find a list of local installers near you!

COPYRIGHT © 2020 SAFEWAY SAFETY STEP, LLC
(DBA "CleanCut") All Rights Reserved

Reproduction or Distribution of this Installation Manual is Strictly Prohibited

**** IMPORTANT – PLEASE WATCH INSTALLATION VIDEOS PRIOR TO READING DIRECTIONS AND BEFORE BEGINNING INSTALLATION ****



Scan QR Code with phone camera to watch **video instructions** or visit www.cleancutbath.com for more resources

IT IS VERY IMPORTANT THAT ALL INSTRUCTIONS IN THE INSTALLATION MANUAL ARE FOLLOWED THOROUGHLY.

INSTALLATION OF THE CLEAN CUT STEP REQUIRES USE OF POTENTIALLY DANGEROUS TOOLS.

SAFEGWAY SAFETY STEP, LLC (DBA "CLEAN CUT") ACCEPTS NO RESPONSIBILITY FOR ANY TYPE OF INJURY, LOSS OR DAMAGE OCCURRED DURING INSTALLATION OR SUBSEQUENT USE OF THE CLEAN CUT STEP.

FAILURE TO FOLLOW THE INSTRUCTIONS IN THIS INSTALLATION MANUAL SHALL VOID ANY WARRANTY GIVEN WITH RESPECT TO THE CLEAN CUT STEP.

IMPORTANT REMINDER - PLEASE REGISTER THE PRODUCT WARRANTY BY VISITING WWW.CLEANCUTBATH.COM/WARRANTY. ADDITIONAL CARE & USE AND WARRANTY INFORMATION IS INCLUDED IN THE KIT.

ADDITIONAL QUESTIONS?

CLEAN CUT CUSTOMER SERVICE REPRESENTATIVES ARE AVAILABLE TO ANSWER QUESTIONS MONDAY-FRIDAY FROM 9AM-4PM EST. FOR QUESTIONS, PLEASE CALL 877-882-7837 OR VISIT WWW.CLEANCUTBATH.COM.

MSDS SHEET FOR ENCLOSED ADHESIVE AVAILABLE UPON REQUEST.

This manual includes an overview of the CleanCut Deep Step kit as well as step-by-step instructions for installation.

CleanCut Deep Step Installation Kit

The CleanCut Deep Step installation kit includes the following items:

- One CleanCut Deep Step (wide or extra-wide)
- One CleanCut Deep Step Support Box Structure (large & small box)
- Template to be used for cutting the tub
- Two tubes of required adhesive and angled extension nozzle

Tools & Materials

In addition to the items included in the installation kit, the following tools and materials are recommended to have on hand for installation.

Additional Tools & Materials

Butane Torch	Mirror (small)
Cardstock Paper	Paper Towels
Caulking Gun	Jigsaw with no more than 1.75" Blade
Chisels	Masking Tape
Deburring Tool (i.e. drywall plane, rasp)	Pliers
Drain Screens	Pressure Treated 2x4's
Drill & Drill Bits	Protective Eye Wear
Drop Cloths	Reciprocating Saw with Metal Blade
Dust Masks	Scissors
Dustpan & Brush	Screwdriver
Ear Protection	Screws- Assorted Sizes
Extension Cord	Sharpie Marker (colored)
Fire Extinguisher	Side Grinder with 4.5" Diamond Blade
Gloves	Utility Knife
Hammer	Vacuum with Attachment
Isopropyl Alcohol	Wood Shims

Preparing the Tub

1. Before beginning any work, it is important to inspect the tub for existing chips, markings or other types of damage. It is always wise to make the owner or manager aware of any existing damage prior to beginning the installation process.
2. Prior to beginning the installation, remove any personal items from the bathroom area to create extra space during the installation and to prevent possible damage or exposure to dust and debris that may result during the installation process.
3. One method to minimize the areas where dust can settle is to use a 2-ply drop cloth with the paper side up to catch and trap dust and other shavings. In particular, a drop cloth should be taped into the bottom of the tub. This will help to collect debris as well as to help prevent accidentally scratching the bottom surface of the tub. The drain of the tub should be completely covered to prevent any shaving from going down into the drain. Make sure that there is no water or dampness in or around the tub.

Due to the significant amount of dust created when cutting a cast-iron tub, it is recommended that all walls and surfaces are covered, including the floor, before cutting the tub. See other considerations for cutting cast-iron tubs in the following section.

4. Confirm that the CleanCut Deep Step will fit the bathtub. First, measure the top rail width measurement as well as the width measurement approximately 11.75" down the tub (bottom measurement). Based on these measurements, please consider the following:
 - Wide: maximum top rail measurement 6.0", maximum bottom rail measurement 7.25"
 - Extra-Wide: maximum top rail measurement 8.0", maximum bottom rail measurement 9.0"
5. Using the template that was included in the installation kit, place the template flush against the tub and begin tracing, use a colored sharpie marker so as to make the lines that are traced easily visible. Flip the template over and now trace the outside of the tub. Keep in mind that it may not be possible to place the CleanCut Deep Step directly in the center of the tub due to obstructions in the tub area such as the placement of sinks, vanities or commodes and the use of shower seats may warrant moving the opening forward as well.

Cutting the Tub

The tub has been marked and is ready to cut.

Safety Considerations

- Safety is of highest importance and it is critical to remember to use the proper safety equipment when cutting the tub.
- Protective eye and ear wear and filter mask are required.
- Be cognizant of potential safety issues when cutting the tub such as sparks generated during cutting as well as items that may be located within the tub wall such as water lines, electrical lines, insulation, etc.

The CleanCut Deep Step can be installed in acrylic, fiberglass, steel or cast-iron tubs. On acrylic, fiberglass or steel tubs, use a side grinder with the diamond blade to make necessary entry points for the reciprocating saw. For cast-

iron tubs, the side grinder with the diamond blade is the only cutting tool used. If you are cutting a cast-iron tub, please read the special considerations noted below before beginning to cut.

1. The first corner notches will be made with the side grinder as illustrated in Figure 1 below.
2. Using the reciprocating saw on acrylic, fiberglass and steel tubs, cut out the bottom markings on each side of the tub.
3. Then cut all four downward cuts. Finish by cutting the two adjoining top pieces.

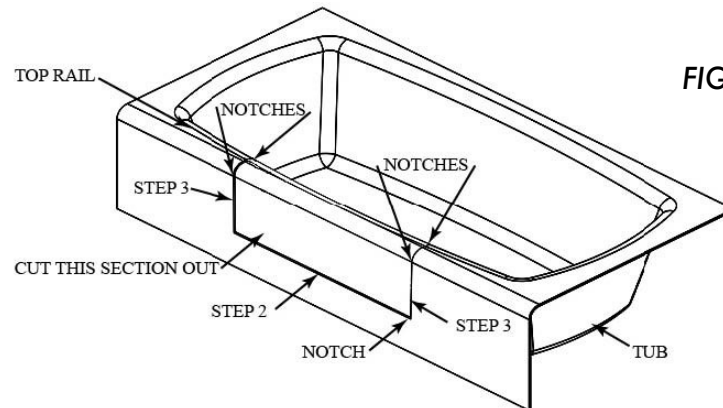

FIGURE 1

4. The opening for the CleanCut Deep Step is now completed and you can remove the cut-out section. Use caution when removing the cut-out section as there may be sharp or jagged edges both on the cut-out segment and along the edges of where the cuts were made on the sides of the tub. It is helpful to spend a moment to file down any potential hazard areas. This prevents potential snags with fitting the CleanCut Deep Step and reduces the risk of injury.
5. After the cut-out section of the tub has been removed, take a few moments to clean the area in and around the tub. Using a dustpan and broom, sweep all dust and shavings. Complete the clean-up by thoroughly vacuuming the entire area. Wash your hands before you start any work on the Deep Step itself. This will eliminate transferring any dirt or dust to the Deep Step.

SPECIAL CONSIDERATIONS FOR CUTTING CAST-IRON TUBS

CleanCut recommends professional installation when installing on cast-iron tubs.

Due to the significant amount of dust created when cutting a cast-iron tub, it is recommended that you cover all tub and exposed bathroom walls and surfaces (including the floor) with a 2-ply drop cloth to minimize the amount of dust that can settle. Also, it is recommended that the installer wears protective coveralls and shoe covers, in addition to protective wear outlined earlier, to minimize the clean-up after cutting out a cast-iron tub.

Please note that there are several differences when cutting out a cast-iron tub compared to other types of tubs. The side-grinder with a 4.5" diamond blade is the only tool used when cutting a cast-iron tub. Cast-iron tubs are a bit more challenging to cut. Vacuum the dust and shavings as you cut the tub. Follow the same pattern when cutting a cast-iron tub as described for the other tub types. Begin by cutting the bottom lines of your template, followed by the downward vertical cuts, leaving the top adjoining pieces for last.

Measuring & Cutting the CleanCut Deep Step

Once you have completed cutting out the section of the tub, you can begin to fit the CleanCut Deep Step into the tub opening. Please note that the Deep Step should be installed with the logo showing on the outside of the tub.

1. Take a stack of heavy cardstock paper. This is the paper used to trace the cut-out section of the tub onto the CleanCut Deep Step. Place the paper onto the left end and trace the outline of the pattern onto the paper. Once completed, mark this tracing as "Left", so as to remember which side was traced. It is also helpful to place an arrow on the template to indicate which direction is the inside of the tub.
2. Repeat the process for the right side of the tub. Mark this tracing "Right".
3. Cut out the paper templates with scissors making sure to keep to the inside of the tracings (Figure 2).

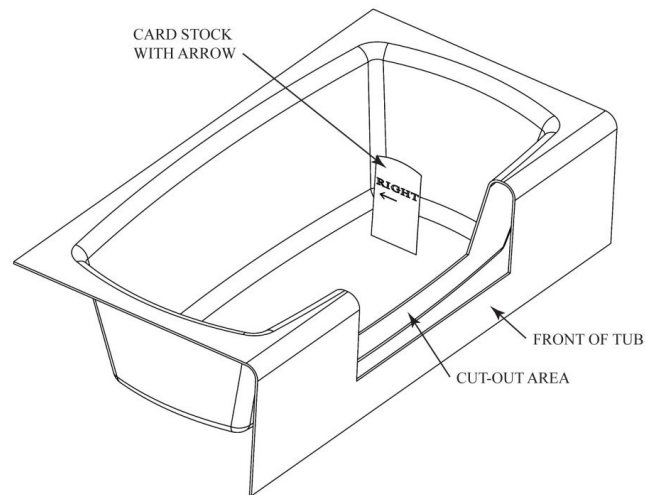
**FIGURE 2**

4. It is time to transfer the shape of our cut tub onto the CleanCut Deep Step. Before continuing, it is recommended that a drop cloth approximately 3' x 4' size be placed on the floor to prevent any dust or other debris from transferring onto the CleanCut Deep Step.

- Place the right end of the CleanCut Deep Step on the ground in order to trace the left side of the CleanCut Deep Step. Place the top of the paper template approximately 1" from the top of the CleanCut Deep Step (Figure 3). Place the tracing on the Deep Step so the slope is similar to that of the tub. Trace the outline of the paper onto the CleanCut Deep Step with a continuous line. Continue the lines with a straight edge down and around the corners. Repeat the same procedure for the right end of the CleanCut Deep Step. Remember to place the paper template approximately 1" down from the top of the CleanCut Deep Step before beginning to trace. Continue the lines with a straight edge down and around the corners.

FIGURE 3 – SIDE VIEW OF LEFT END OF DEEP STEP

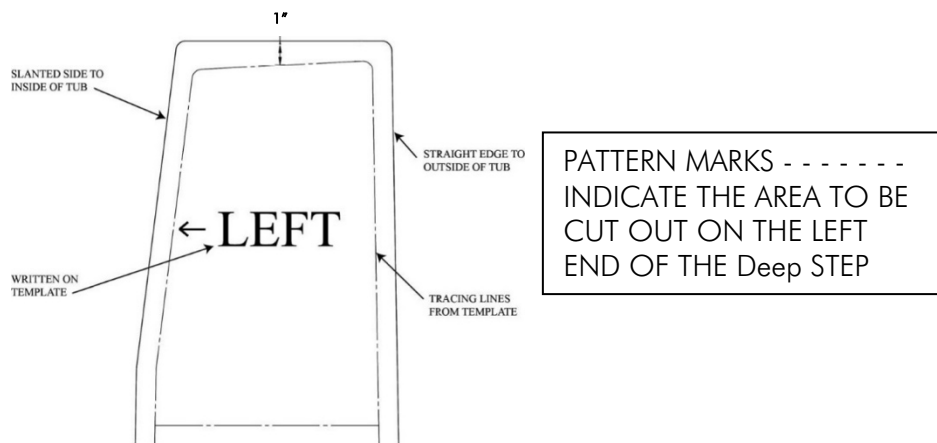

- Place CleanCut Deep Step as shown in Figure 4. Use a tape measure and transfer the shape of the inside of the tub edge to the Deep Step. The inside of the tub may be irregular in shape, so measurements for the inside line must be made every 3" from one end of the Deep Step to the other. Once completed, use your yard stick and marker to connect the markings for the inside line.

Alternate Method: You may use cardstock paper such as done with the sides to create a bottom template.

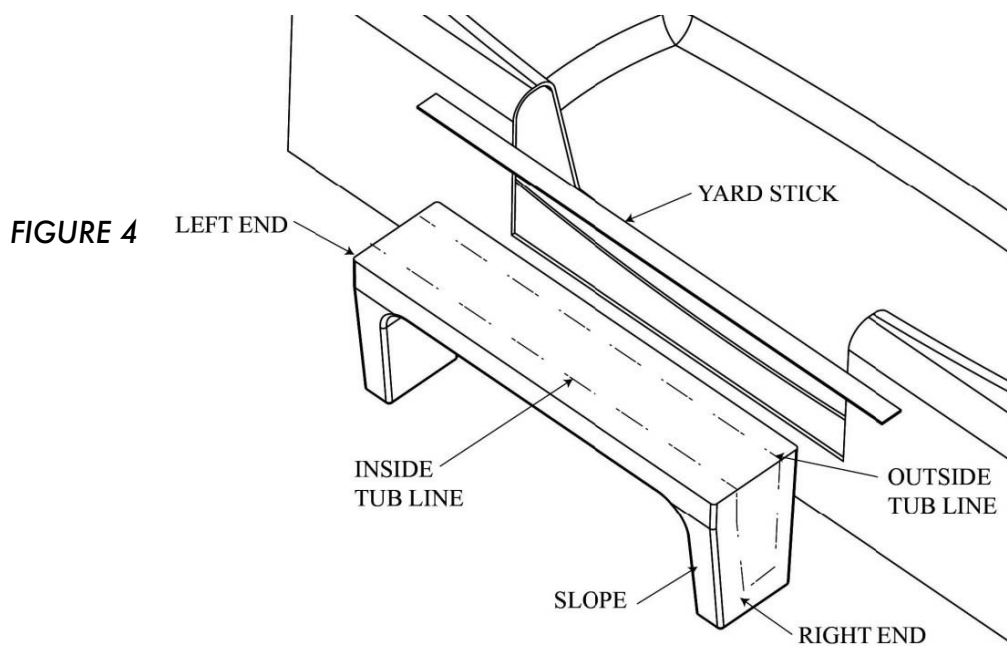

Support Box Structure Installation

Once the CleanCut Deep Step has been cut and a satisfactory fit into the tub opening has been achieved, it will be necessary to assemble the support box structure to provide support to the CleanCut Deep Step. An example of the CleanCut Deep Step and the support box structure is illustrated in Figure 6.

The CleanCut Support box structure consists of one small and one large support box. The large support box will compress over the top of the small box to the necessary height to provide support to the CleanCut Deep Step.

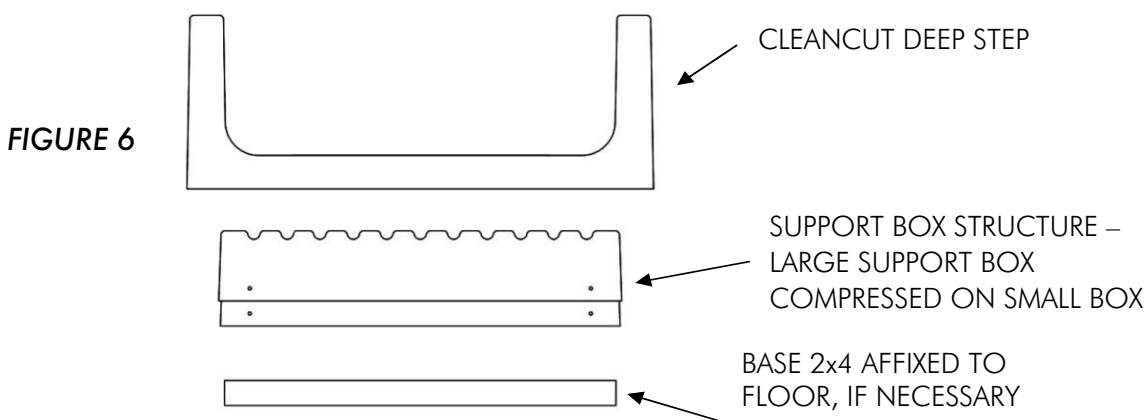

It is important to understand that each tub has variations and modifications may be necessary in the field. For fiberglass and other types of tubs, it may be necessary to adjust the installation of the support boxes based on the framing or support material present on the inside channel of the tub. For example, you may only need to use one of the support structures based on the height of the bathtub.

1. It may be necessary to adjust the support box structure according to the conditions present during your installation. For example, for wooden sub-floors, begin by screwing or adhering with included adhesive a treated 2x4 directly to the sub-floor to serve as a base for the support structure. For concrete floors, a treated 2x4 is adhered directly to the concrete floor with adhesive. The 2x4 might need to be cut into several sections if there is a support brace in the cut-out channel.
2. Build the support box structure to appropriate height. If working with a concrete sub-floor, thoroughly inspect and clean the floor in the tub cut-out channel prior to securing the treated 2x4. Remove any materials from the concrete that may cause an uneven surface. Apply adhesive directly to the concrete floor. Insert the 2x4s and thoroughly spread the adhesive on the concrete.

3. Prior to inserting the small support box, it is necessary to secure a 22½" long 2x4 into the channel of the small support box. Place a bead of adhesive around the inside of the support box and insert the 2x4. Place several screws into the small support box to affix the 2x4 into proper position (Figure 7).

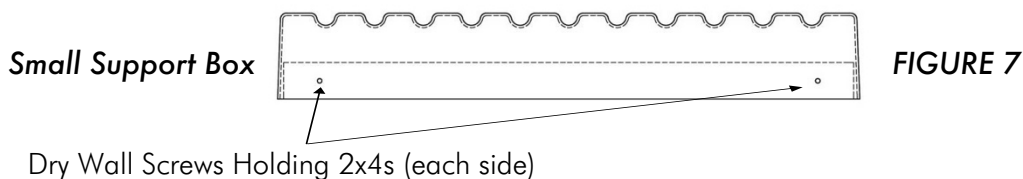

4. Insert the small box in the channel. At this point, do not adhere the small support box to anything. Place the large support box into the channel and over the top of the small box. Place the CleanCut Deep Step into position and compress the CleanCut Deep Step downward to determine the proper height and placement for the support box structure.
5. Once the support of the CleanCut Deep Step has been achieved, remove the Deep Step and mark both the left and right ends of the small box where the large box is compressed while the boxes are in the tub opening channel. Once properly marked, remove both support boxes and label the markings "Left" and "Right" to avoid potential confusion. Uncompress the two support boxes from one another and begin the process to permanently adhere the boxes in proper position.
6. Apply adhesive around perimeter of the large box. Compress small and large support box structures back together to the appropriate markings made earlier on small box. Place the support structure back into the channel and insert the CleanCut Deep Step to verify that proper placement has been achieved. Secure both sides of the support structure by placing two screws in each side (Figure 8).

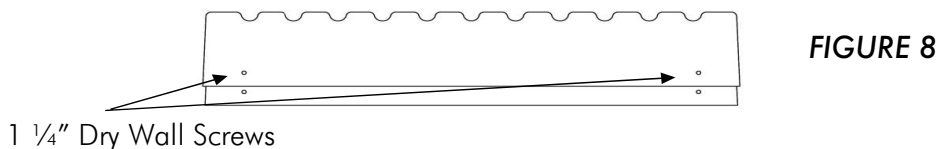

7. Apply adhesive to the tops of the 2x4s that are already in place in the channel if they are needed for height adjustment and insert the support box structure.
8. Place the CleanCut Deep Step into position once more to inspect the fit and position. This is the final opportunity to make any adjustments if necessary.
9. Apply adhesive to the top of the large support box. It is recommended that an extra bead of adhesive be placed on the ends of the large support box as the Deep Step curves up toward the ends. Place a substantial bead of adhesive on the top left and right side of the tub where the CleanCut Deep Step will be seated. Adhesive on the top of the tub reinforces the CleanCut Deep Step.
10. Prior to placing the CleanCut Deep Step into the channel, it is necessary to gently pass a low flame several times along the perimeter of the Deep Step where the tub is met. This will help promote bonding between the Deep Step and the bathtub where adhesive is applied. Use caution when using the torch and do not hold heat on area of the product as it may discolor or melt.
11. Place the CleanCut Deep Step into the channel and gently press into place.

Completing the Installation

1. Before finalizing the installation, make sure the CleanCut Deep Step is in proper position and fully compressed. Press firmly and evenly on the CleanCut Deep Step to ensure proper placement. Thoroughly wipe the tub area with isopropyl alcohol where the adhesive will bond and allow enough time for the isopropyl alcohol to flash off before applying the adhesive. **Do not** apply the isopropyl alcohol directly on the adhesive as it will prevent the adhesive from drying or curing. **Do not** use to clean or smooth your final bead.
2. It is necessary to caulk around the entire perimeter of the CleanCut Deep Step using the enclosed adhesive. Begin by using the adhesive along the sides of the CleanCut Deep Step. Begin on the left side and complete the process, before moving to the right side and bottom. It is recommended that you wear gloves during this step to avoid direct exposure to the adhesive.
3. Run your gloved finger along the beads and wipe the excess on a folded paper towel. Try to smooth the beads one-time only, as the adhesive becomes tacky to the touch quickly.
4. Underneath the bottom edges of the CleanCut Deep Step are more difficult to see and the included angled nozzle should be used in completing this step. Use a small mirror to inspect the bead and to verify that all surfaces have been properly sealed.
5. It is recommended to remove the stopper from the tub upon completion of installation to prevent from accidentally filling the tub with water and, if desired, replace trip lever with a blank cap.
6. Spend a few minutes at the end of the job to once again clean up the tub and the bathroom area. Upon completion, place a sign on the CleanCut Deep Step warning not to use the tub for 2 days while the adhesive cures.

IMPORTANT REMINDER – if completing the install on behalf of another, please leave the warranty and care & use information with the end-user at the conclusion of the installation.

The CleanCut Deep Step installation is now complete. Safeway Safety Step, LLC (DBA CleanCut) sincerely thanks you for your interest in the CleanCut Deep Step and looks forward to assisting you in any way possible. Visit our website at www.cleancutbath.com for video installation instructions and answers to frequently asked questions or call us toll-free at 877-882-7837 with any questions or concerns.